

仕様書番号

BSW36372 - a

仕 様 書

三相 4 線 式

発信装置付普通電力量計 (変成器付)

A 4 6 A - K 8 0 V R 形 (5 A)

	資料番号
仕 様	BSW310283 - a
構 造 図	BSW311196
外形寸法図	BSW312124
接 続 図	BSW313224, 313225
テクニカルデータ	BSW314269
特性・曲線	BSW315103
定 数 表	BSW316167~316170

2009年5月1日作成

承認	調査	作成
		

発信装置付普通電力量計（変成器付）仕様

この仕様は、計器用変成器とともに取付けて、電力取引に使用する発信装置付普通電力量計に適用する。

1. 名称および形式

名 称	発信装置付普通電力量計（変成器付）
電 気 方 式	三相4線式
形 名	A46A-K80VR形
型式承認番号	第2379-3号

2. 定 格

定 格 電 圧	100/173, 240/415, 110/190, $(110/\sqrt{3})/110V$
定 格 電 流	/5A
定 格 周 波 数	50, 60Hz
計 器 定 数	1600 rev/kWh (100/173, 110/190Vの場合) 666 $2/3$ rev/kWh (240/415Vの場合) 2666 $2/3$ rev/kWh ($(110/\sqrt{3})/110V$ の場合)
出力パルス定数	$1/10^{n+1}$, $1/10^n$, $1/10^{n-1}$, $1/10^{n-2}$ pulse/kWh (変成器一次側) ※ 10^n : 計器の乗率と同じ

3. 構 造

- | | |
|-----------|---|
| 3.1 一般構造 | 発信装置付普通電力量計（変成器付）として長期間の使用に十分耐える構造をもつものである。 |
| 3.2 接続・取付 | 背面接続・背面取付 |
| 3.3 外面塗装色 | 前面カバー マンセル値 N1.5 または 7.5BG 4/1.5
その他 マンセル値 N5 |
| 3.4 計量装置 | 計量装置は現字形5桁で回転子軸から歯車を介して、直接駆動するものである。乗率は10の整数べき倍である。 |
| 3.5 回転子軸受 | 上部軸受は針状式、下部軸受は二重宝石式である。 |
| 3.6 封印装置 | 計器の前面カバー締付ねじ（上下2箇所）には、封印可能な構造を備えている。 |
| 3.7 調整装置 | 各種調整装置は、調整が容易で、他特性への干渉が少なく調整後は確実に固定される。 |
| 3.8 発信装置 | 回転子に取付けられた信号円板により光結合素子で信号を発生させて、定格に応じた分周を行い、単位電力量当たりの無電圧接点パルスを発信する。出力は水銀接点出力となっているため接点容量が大きい。 |

4. 計器質量	約 3.8kg
---------	---------

構造図

三相4線式

発信装置付普通電力量計 (変成器付)

A46A-K80VR形 (5A)

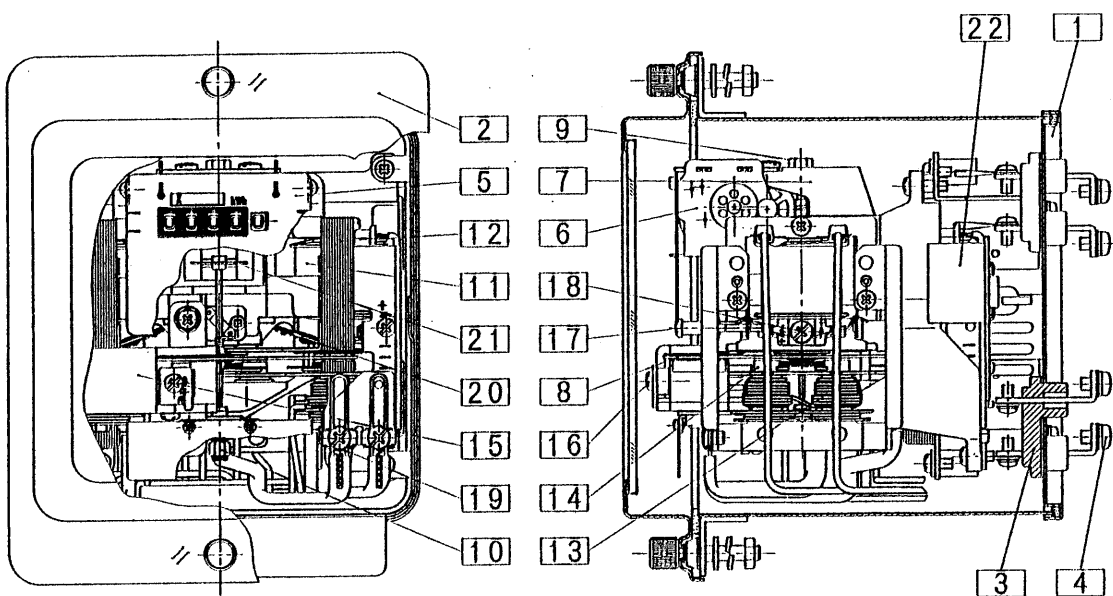

22	電源部・演算部プリント板	
21	受信部プリント板	光結合素子2相受け
20	遅相板	アルミニウム、第二温度補償片付
19	位相調整装置	抵抗線スライド式
18	トルクバランス調整ねじ	微調整式
17	軽負荷調整ねじ	微調整式
16	重負荷調整ねじ	微調整式
15	制動磁石	MK鋼、第一温度補償片付
14	電流鉄心	けい素鋼板
13	電流コイル	ホルマール銅線
12	電圧鉄心	けい素鋼板
11	電圧コイル	ポリウレタン銅線
10	下部軸受	二重宝石式
9	上部軸受	ステンレスピン
8	円板	アルミニウム、上面100等分目盛付
7	支持枠	アルミニウム合金ダイカスト
6	計量装置	5桁数字車、ポリアセタール樹脂
5	銘板	アルミニウム
4	電線接続端子	M5ねじ
3	端子盤	フェノール樹脂
2	カバー	鋼板、ガラス窓付
1	ベース	鋼板
項	部品名	特記事項

外形寸法図

三相4線式

発信装置付普通電力量計 (変成器付)

A46A-K80VR形・A46A-K9V形 (5A)

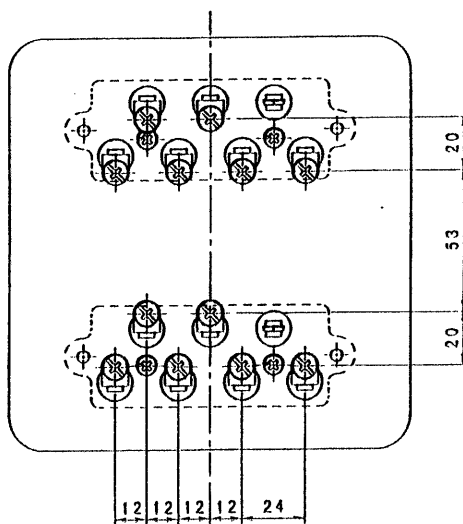
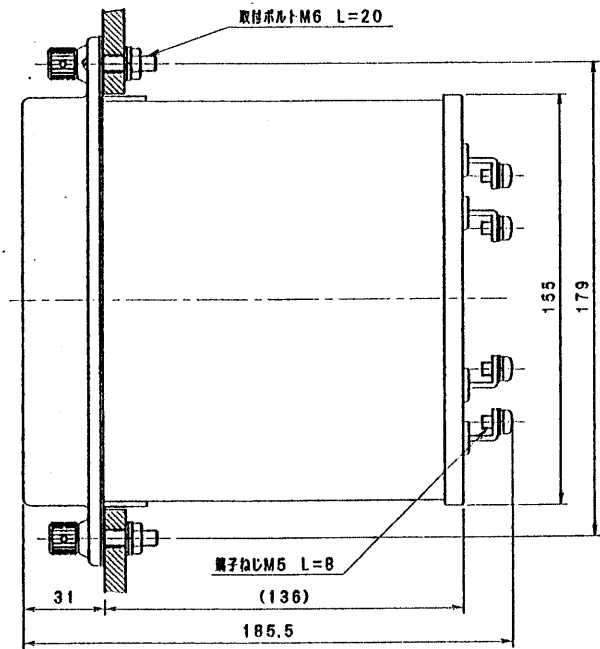
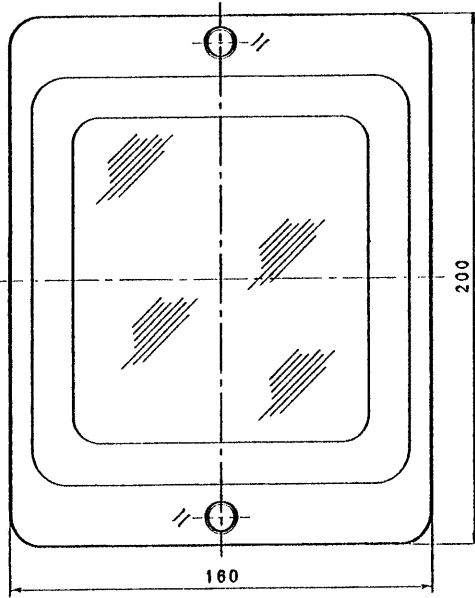

端子配列

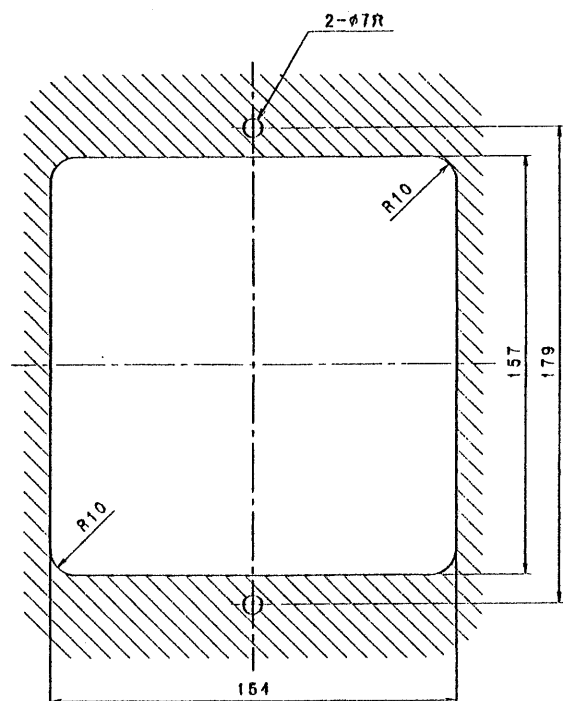

パネル穴加工図

接 続 図

三相 4 線式

発信装置付普通電力量計 (VCT付)

A46A-K80VR形 (5A)

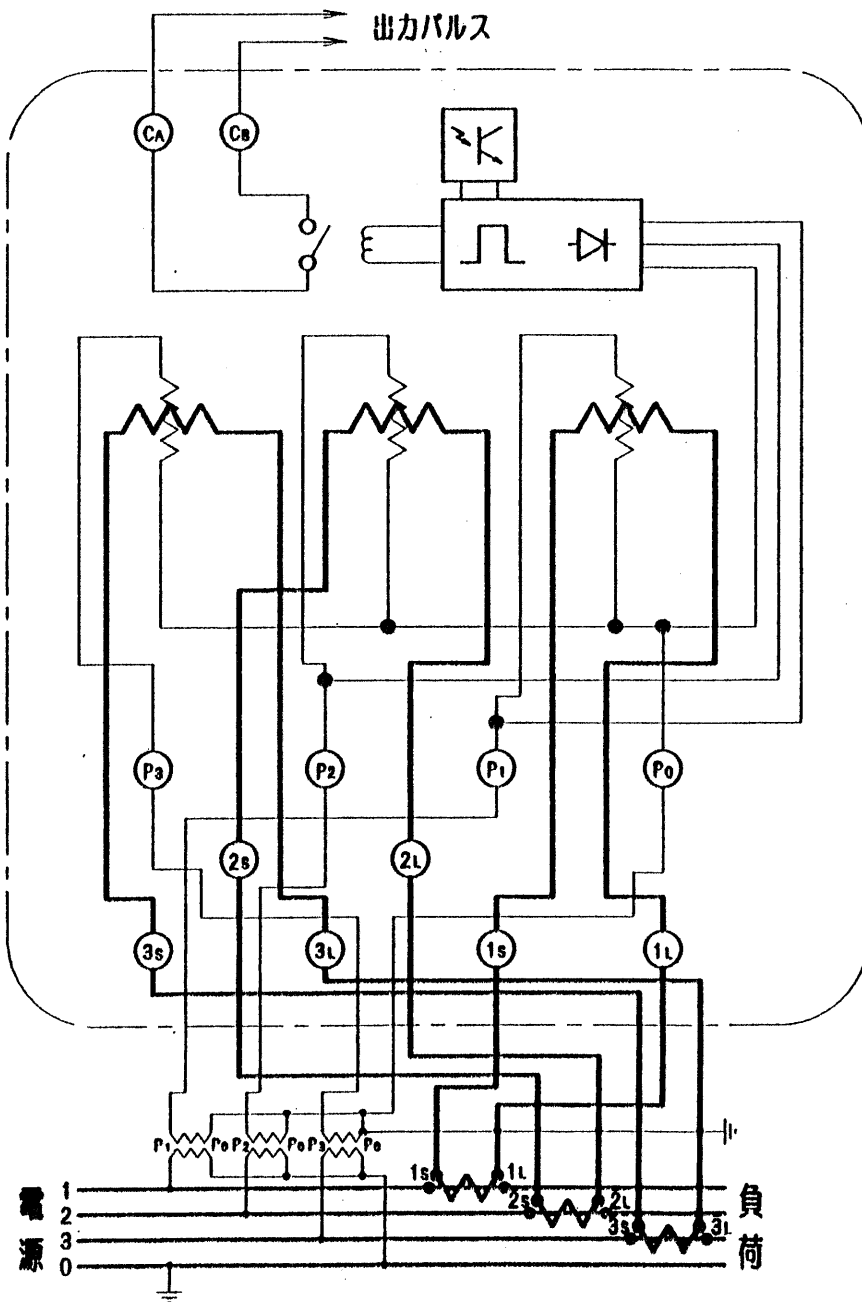

接続図

三相4線式

発信装置付普通電力量計 (CT付)

A46A-K80VR形 (5A)

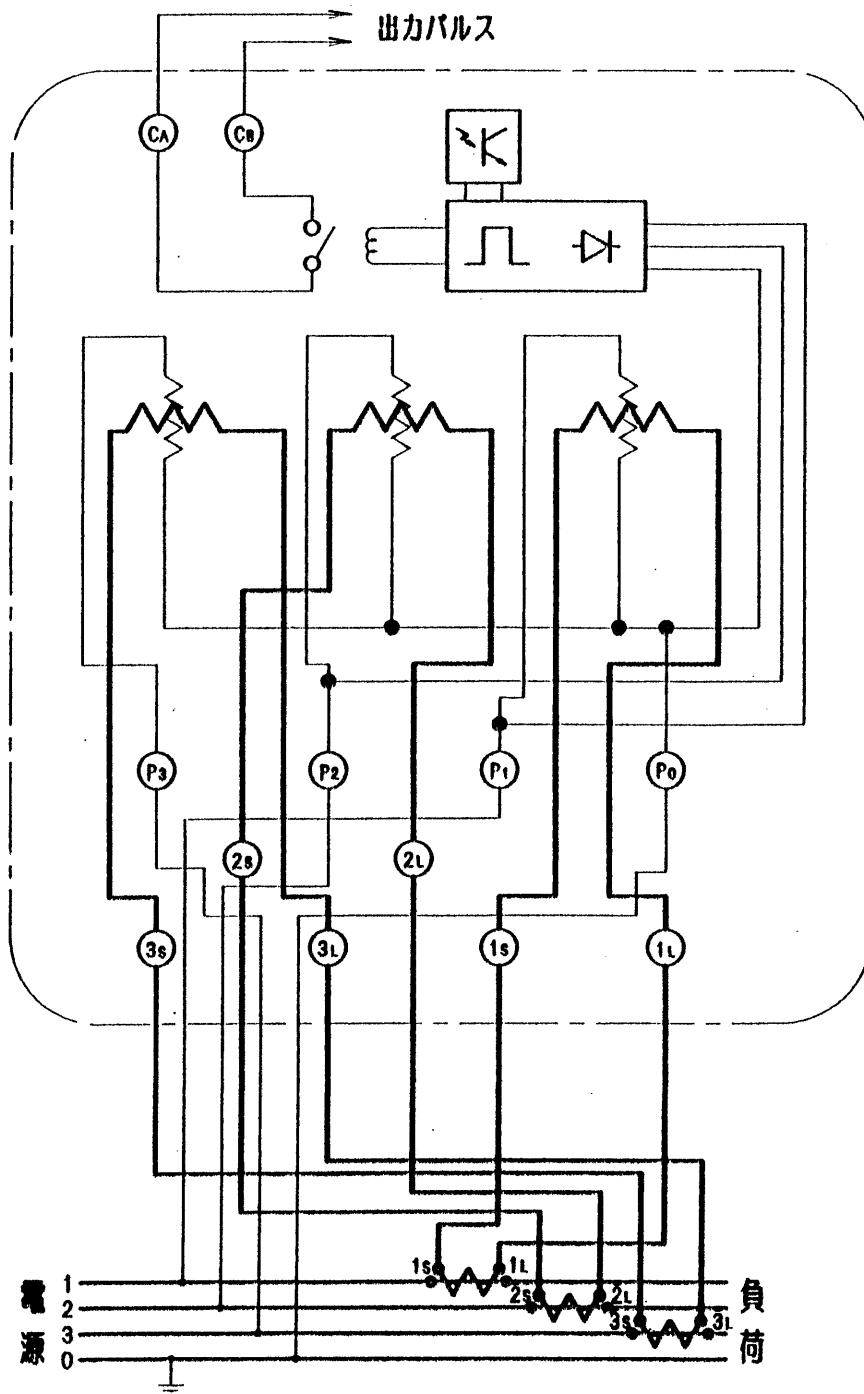

テクニカルデータ

項	項目	単位	仕様				備考
1	電気方式	—	三相 4 線式				
2	形名	—	A46A-K80R , A46A-K80VR				
3	準拠規格	—	JIS C 1216				
4	定格電圧	V	100/173	240/415	110/190	$\frac{110/\sqrt{3}}{110}$	
5	定格電流	A	5				
6	定格周波数	Hz	50, 60				
7	計器定数	rev/kWh	1600	666 2/3	1600	2666 2/3	
8	出力パルス定数 (変成器一次側)	$\frac{\text{pulse}}{\text{kWh}}$	$\frac{1}{10^{n+1}}$ $\frac{1}{10^n}$ (標準品) $\frac{1}{10^{n-1}}$ $\frac{1}{10^{n-2}}$				定数表参照
9	全負荷速度	rpm	40	44	42.3		
10	全負荷回転力	$\mu\text{N}\cdot\text{m}$	1872	2058	1872		
11	回転子質量	g	28.5				
12	回転力/回転子質量	—	65.7	72.2	65.7		
13	始動電流 (En, fn)	mA	20 以下で 1 回転以上回転しない				
14	電圧潜動 (fn, 無負荷)	—	110% En で 1 回転しない				
15	電圧回路皮相電力	VA	P1-P0	1.9 (50Hz), 2.6 (60Hz)	110/190V にて		
			P2-P0	5.3 (50Hz), 4.3 (60Hz)			
			P3-P0	5.1 (50Hz), 4.3 (60Hz)			
16	電圧回路電力損失	W	P1-P0	1.6 (50Hz), 1.6 (60Hz)	"		
			P2-P0	1.0 (50Hz), 0.8 (60Hz)			
			P3-P0	1.0 (50Hz), 0.8 (60Hz)			
17	電流回路皮相電力	VA	2.1 (50Hz), 2.3 (60Hz)	5Aにて			
18	電流回路電力損失	W	1.4 (50Hz), 1.5 (60Hz)	"			
19	計器誤差 (En, fn) pf1.0 5~120%(In) pf0.5 遅れ 10~120%(In)	%	±2.0 以下 ±2.5 以下				
20	出力パルス容量	—	AC 25VA 以下 110V 以下 0.5A 以下 DC 10VA 以下 110V 以下 0.1A 以下				
21	出力パルス幅	msec	120±5(標準品), 200±5				
22	使用周囲温度	°C	-10 ~ +40				
23	絶縁抵抗試験 (DC 500V)	MΩ	電気回路とベース間, 電気回路相互間……100 以上				
24	商用周波耐電圧 (AC, 1 分間印加)	kV	電気回路とベース間, 電気回路相互間……2 以上				
25	雷インパルス耐電圧 (1×40μs)	kV	電気回路相互間……6 以上				

特性・曲線

三相 4 線式

110/√3/110, 100/173, 110/190, 240/415V 5A 50, 60Hz

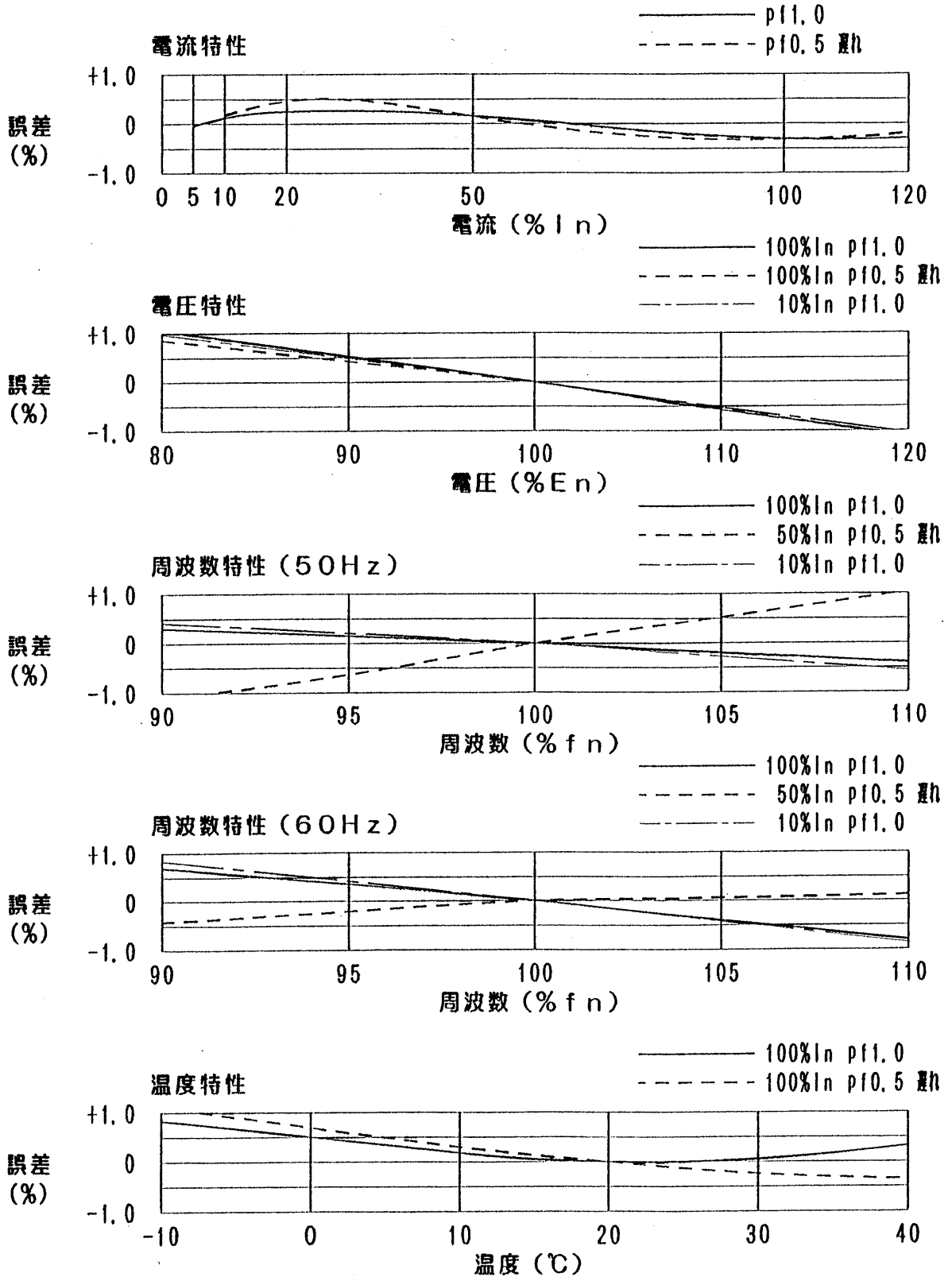

定数表

二次側計器定数 1600 rev/kWh

三相4線式 発信装置付普通電力量計 (CT付)

	定格電圧 (V)	全負荷 電力 (kW)	計量装置		一次側 計器定数 (rev/kWh)	一次側発信定数 (pulse/kWh)			
	100/173		読み (kWh)	乗率		$1/10^{n+1}$	$1/10^n$	$1/10^{n-1}$	$1/10^{n-2}$
CT 一次側 定格電流 (A) (二次側 定格電流 5A)	40	12	00000	×1	200	1/10	1	10	100
	50	15	"	"	160	"	"	"	"
	60	18	"	"	133 1/3	"	"	"	"
	75	22.5	"	"	※ 100	"	"	"	"
	80	24	"	"	100	"	"	"	"
	100	30	"	"	80	"	"	"	"
	150	45	"	"	53 1/3	"	"	"	"
	200	60	"	"	40	"	"	"	"
	250	75	"	"	32	"	"	"	"
	300	90	"	"	26 2/3	"	"	"	"
	400	120	"	×10	20	1/100	1/10	1	10
	500	150	"	"	16	"	"	"	"
	600	180	"	"	13 1/3	"	"	"	"
	750	225	"	"	※ 10	"	"	"	"
	800	240	"	"	10	"	"	"	"
	1000	300	"	"	8	"	"	"	"
	1200	360	"	"	6 2/3	"	"	"	"
	1500	450	"	"	5 1/3	"	"	"	"
	2000	600	"	"	4	"	"	"	"
3000	900	"	"	2 2/3	"	"	"	"	

注) ※は計器製作の都合上、二次側計器定数が 1500 rev/kWh となります。

定 数 表

二次側計器定数 666 2/3 rev/kWh

三相 4 線式 発信装置付普通電力量計 (CT付)

	定格電圧 (V)	全負荷 電力 (kW)	計量装置		一次側 計器定数 (rev/kWh)	一次側発信定数 (pulse/kWh)			
	240/415		読み (kWh)	乗率		$1/10^{n+1}$	$1/10^n$	$1/10^{n-1}$	$1/10^{n-2}$
CT 一次側 定格電流 (A) (二次側 定格電流 5A)	15	10.8	00000	×1	222 2/9	1/10	1	10	100
	20	14.4	"	"	166 2/3	"	"	"	"
	30	21.6	"	"	111 1/9	"	"	"	"
	40	28.8	"	"	83 1/3	"	"	"	"
	50	36	"	"	66 2/3	"	"	"	"
	60	43.2	"	"	55 5/9	"	"	"	"
	75	54	"	"	44 4/9	"	"	"	"
	80	57.6	"	"	41 2/3	"	"	"	"
	100	72	"	"	33 1/3	"	"	"	"
	150	108	"	×10	22 2/9	1/100	1/10	1	10
	200	144	"	"	16 2/3	"	"	"	"
	250	180	"	"	13 1/3	"	"	"	"
	300	216	"	"	11 1/9	"	"	"	"
	400	288	"	"	8 1/3	"	"	"	"
	500	360	"	"	6 2/3	"	"	"	"
	600	432	"	"	5 5/9	"	"	"	"
750	540	"	"	4 4/9	"	"	"	"	
800	576	"	"	4 1/6	"	"	"	"	
1000	720	"	"	3 1/3	"	"	"	"	
1200	864	"	"	2 7/9	"	"	"	"	

定数表

三相4線式 発信装置付普通電力量計 (VT, CT付)

二次側計器定数 1600 rev/kWh

	VT一次側定格電圧 (V) (二次側定格電圧は 110V)							合成 変成 比	計量装置		一次側 計器定数 (rev/kWh)	一次側発信定数 (pulse/kWh)			
	440	3300	6600	11000	22000	33000	66000		読み (kWh)	乗率		1/10 ⁿ⁺¹	1/10 ⁿ	1/10 ⁿ⁻¹	1/10 ⁿ⁻²
	15							12	00000	×1	133 1/3	1/10	1	10	100
	20							16	〃	〃	100	〃	〃	〃	〃
	30							24	〃	〃	66 2/3	〃	〃	〃	〃
	40							32	〃	〃	50	〃	〃	〃	〃
	50							40	〃	〃	40	〃	〃	〃	〃
	60							48	〃	〃	33 1/3	〃	〃	〃	〃
	75	10						60	〃	〃	26 2/3	〃	〃	〃	〃
	80							64	〃	×10	25	1/100	1/10	1	10
	100							80	〃	〃	20	〃	〃	〃	〃
		15						90	〃	〃	17 7/9	〃	〃	〃	〃
	150	20	10					120	〃	〃	13 1/3	〃	〃	〃	〃
	200							160	〃	〃	10	〃	〃	〃	〃
		30	15					180	〃	〃	8 8/9	〃	〃	〃	〃
				10				200	〃	〃	8	〃	〃	〃	〃
	300	40	20					240	〃	〃	6 2/3	〃	〃	〃	〃
		50		15				300	〃	〃	5 1/3	〃	〃	〃	〃
	400							320	〃	〃	5	〃	〃	〃	〃
		60	30					360	〃	〃	4 4/9	〃	〃	〃	〃
	500			20	10			400	〃	〃	4	〃	〃	〃	〃
		75						450	〃	〃	3 5/9	〃	〃	〃	〃
	600	80	40					480	〃	〃	3 1/3	〃	〃	〃	〃
	750	100	50	30	15	10		600	〃	〃	2 2/3	〃	〃	〃	〃
	800							640	〃	×100	2 1/2	1/1000	1/100	1/10	1
			60					720	〃	〃	2 2/9	〃	〃	〃	〃
	1000			40	20			800	〃	〃	2	〃	〃	〃	〃
		150	75			15		900	〃	〃	1 7/9	〃	〃	〃	〃
	1200		80					960	〃	〃	1 2/3	〃	〃	〃	〃
				50				1000	〃	〃	1 3/5	〃	〃	〃	〃
	1500	200	100	60	30	20	10	1200	〃	〃	1 1/3	〃	〃	〃	〃
				75				1500	〃	〃	※ 1	〃	〃	〃	〃
	2000			80	40			1600	〃	〃	1	〃	〃	〃	〃
		300	150			30	15	1800	〃	〃	8/9	〃	〃	〃	〃
				100	50			2000	〃	〃	4/5	〃	〃	〃	〃
	3000	400	200		60	40	20	2400	〃	〃	2/3	〃	〃	〃	〃
		500		150	75	50		3000	〃	〃	8/15	〃	〃	〃	〃
	4000				80			3200	〃	〃	1/2	〃	〃	〃	〃
		600	300			60	30	3600	〃	〃	4/9	〃	〃	〃	〃
	5000			200	100			4000	〃	〃	2/5	〃	〃	〃	〃
		750				75		4500	〃	〃	16/45	〃	〃	〃	〃
		800	400			80	40	4800	〃	〃	1/3	〃	〃	〃	〃
		1000	500	300	150	100	50	6000	〃	〃	4/15	〃	〃	〃	〃
		1200	600				60	7200	〃	×1000	2/9	1/10000	1/1000	1/100	1/10
				400	200			8000	〃	〃	1/5	〃	〃	〃	〃
		1500	750			150	75	9000	〃	〃	8/45	〃	〃	〃	〃
			800				80	9600	〃	〃	1/6	〃	〃	〃	〃
				500				10000	〃	〃	4/25	〃	〃	〃	〃
		2000	1000	600	300	200	100	12000	〃	〃	2/15	〃	〃	〃	〃
			1200					14400	〃	〃	1/9	〃	〃	〃	〃
				750				15000	〃	〃	※ 1/10	〃	〃	〃	〃
				800	400			16000	〃	〃	1/10	〃	〃	〃	〃
	3000	1500				300	150	18000	〃	〃	4/45	〃	〃	〃	〃
				1000	500			20000	〃	〃	2/25	〃	〃	〃	〃
	4000	2000	1200	600	400	200		24000	〃	〃	1/15	〃	〃	〃	〃
		5000		1500	750	500		30000	〃	〃	4/75	〃	〃	〃	〃
					800			32000	〃	〃	1/20	〃	〃	〃	〃
			3000			600	300	36000	〃	〃	2/45	〃	〃	〃	〃
				2000	1000			40000	〃	〃	1/25	〃	〃	〃	〃
						750		45000	〃	〃	8/225	〃	〃	〃	〃
		4000		1200	800	400		48000	〃	〃	1/30	〃	〃	〃	〃
		5000	3000	1500	1000	500		60000	〃	〃	2/75	〃	〃	〃	〃
					1200	600		72000	〃	×10000	1/45	1/100000	1/10000	1/1000	1/100
					4000	2000		80000	〃	〃	1/50	〃	〃	〃	〃
						1500	750	90000	〃	〃	4/225	〃	〃	〃	〃
						800		96000	〃	〃	1/60	〃	〃	〃	〃
				5000				100000	〃	〃	2/125	〃	〃	〃	〃
					3000	2000	1000	120000	〃	〃	1/75	〃	〃	〃	〃
					4000			160000	〃	〃	1/100	〃	〃	〃	〃
						3000	1500	180000	〃	〃	2/225	〃	〃	〃	〃
					5000			200000	〃	〃	1/125	〃	〃	〃	〃

注) ※は計器製作の都合上、二次側計器定数が 1500 rev/kWh となります。

定数表

三相4線式 発信装置付普通電力量計 (VT, CT付)

二次側計器定数 2666 2/3 rev/kWh

CT一次側定格電流 (A)	VT一次側定格電圧 (V) (二次側定格電圧は 110/√3V)							合成 変成 比	計量装置		一次側 計器定数 (rev/kWh)	一次側発信定数 (pulse/kWh)			
	440	3300	6600	11000	22000	33000	66000		読み (kWh)	乗率		1/10 ⁿ⁺¹	1/10 ⁿ	1/10 ⁿ⁻¹	1/10 ⁿ⁻²
	√3	√3	√3	√3	√3	√3	√3					×1	×10	×100	×1000
	15							12	00000	×1	222 2/9	1/10	1	10	100
	20							16	"	"	166 2/3	"	"	"	"
	30							24	"	"	111 1/9	"	"	"	"
	40							32	"	"	83 1/3	"	"	"	"
	50							40	"	"	66 2/3	"	"	"	"
	60							48	"	"	55 5/9	"	"	"	"
	75	10						60	"	"	44 4/9	"	"	"	"
	80							64	"	"	41 2/3	"	"	"	"
	100							80	"	"	33 1/3	"	"	"	"
		15						90	"	"	※1 27 7/9	"	"	"	"
	150	20	10					120	"	×10	22 2/9	1/100	1/10	1	10
	200							160	"	"	16 2/3	"	"	"	"
		30	15					180	"	"	※1 13 8/9	"	"	"	"
				10				200	"	"	13 1/3	"	"	"	"
	300	40	20					240	"	"	11 1/9	"	"	"	"
		50		15				300	"	"	8 8/9	"	"	"	"
	400							320	"	"	8 1/3	"	"	"	"
		60	30					360	"	"	7 11/27	"	"	"	"
	500			20	10			400	"	"	6 2/3	"	"	"	"
		75						450	"	"	5 25/27	"	"	"	"
	600	80	40					480	"	"	5 5/9	"	"	"	"
	750	100	50	30	15	10		600	"	"	4 4/9	"	"	"	"
	800							640	"	"	4 1/6	"	"	"	"
			60					720	"	"	※1 3 17/36	"	"	"	"
	1000			40	20			800	"	"	3 1/3	"	"	"	"
		150	75			15		900	"	"	※1 2 7/9	"	"	"	"
	1200		80					960	"	"	2 7/9	"	"	"	"
				50				1000	"	"	2 2/3	"	"	"	"
	1500	200	100	60	30	20	10	1200	"	×100	2 2/9	1/1000	1/100	1/10	1
				75				1500	"	"	1 7/9	"	"	"	"
	2000			80	40			1600	"	"	1 2/3	"	"	"	"
		300	150			30	15	1800	"	"	※1 1 7/18	"	"	"	"
				100	50			2000	"	"	1 1/3	"	"	"	"
	3000	400	200		60	40	20	2400	"	"	1 1/9	"	"	"	"
		500		150	75	50		3000	"	"	8/9	"	"	"	"
	4000				80			3200	"	"	5/6	"	"	"	"
		600	300			60	30	3600	"	"	20/27	"	"	"	"
	5000			200	100			4000	"	"	2/3	"	"	"	"
		750				75		4500	"	"	16/27	"	"	"	"
		800	400			80	40	4800	"	"	5/9	"	"	"	"
		1000	500	300	150	100	50	6000	"	"	4/9	"	"	"	"
		1200	600			60	7200	7200	"	"	※1 25/72	"	"	"	"
				400	200			8000	"	"	1/3	"	"	"	"
		1500	750			150	75	9000	"	"	※1 5/18	"	"	"	"
			800			80	9600	9600	"	"	5/18	"	"	"	"
				500			10000	10000	"	"	4/15	"	"	"	"
		2000	1000	600	300	200	100	12000	"	×1000	2/9	1/10000	1/1000	1/100	1/10
			1200					14400	"	"	※2 3/16	"	"	"	"
				750				15000	"	"	8/45	"	"	"	"
				800	400			16000	"	"	1/6	"	"	"	"
		3000	1500			300	150	18000	"	"	※1 5/36	"	"	"	"
				1000	500			20000	"	"	2/15	"	"	"	"
		4000	2000	1200	600	400	200	24000	"	"	1/9	"	"	"	"
		5000		1500	750	500		30000	"	"	4/45	"	"	"	"
					800			32000	"	"	1/12	"	"	"	"
			3000			600	300	36000	"	"	2/27	"	"	"	"
				2000	1000			40000	"	"	1/15	"	"	"	"
						750		45000	"	"	8/135	"	"	"	"
			4000		1200	800	400	48000	"	"	1/18	"	"	"	"
			5000	3000	1500	1000	500	60000	"	"	2/45	"	"	"	"
					1200	600		72000	"	"	※1 5/144	"	"	"	"
				4000	2000			80000	"	"	1/30	"	"	"	"
						1500	750	90000	"	"	※1 1/36	"	"	"	"
						800	96000	96000	"	"	1/36	"	"	"	"
				5000			100000	100000	"	"	2/75	"	"	"	"
					3000	2000	1000	120000	"	×10000	1/45	1/100000	1/10000	1/1000	1/100
					4000			160000	"	"	1/60	"	"	"	"
						3000	1500	180000	"	"	※1 1/72	"	"	"	"
					5000			200000	"	"	1/75	"	"	"	"

注) ※1, ※2 は計器製作の都合上、二次側計器定数が次の様になります。

※1 = 2500 rev/kWh, ※2 = 2700 rev/kWh